

CZT3019
SURFACE MOUNT
NPN SILICON TRANSISTOR

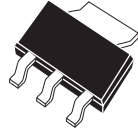

SOT-223 CASE

CentralTM

Semiconductor Corp.

DESCRIPTION:

The CENTRAL SEMICONDUCTOR CZT3019 type is an NPN silicon transistor manufactured by the epitaxial planar process, epoxy molded in a surface mount package, designed for high current general purpose amplifier applications.

MARKING CODE: FULL PART NUMBER

MAXIMUM RATINGS: ($T_A=25^\circ\text{C}$)

	SYMBOL		UNITS
Collector-Base Voltage	V_{CB0}	120	V
Collector-Emitter Voltage	V_{CEO}	80	V
Emitter-Base Voltage	V_{EBO}	7.0	V
Collector Current	I_C	1.0	A
Peak Collector Current	I_{CM}	1.5	A
Power Dissipation	P_D	2.0	W
Operating and Storage			
Junction Temperature	T_J, T_{stg}	-65 to +150	$^\circ\text{C}$
Thermal Resistance	θ_{JA}	62.5	$^\circ\text{C/W}$

ELECTRICAL CHARACTERISTICS: ($T_A=25^\circ\text{C}$ unless otherwise noted)

SYMBOL	TEST CONDITIONS	MIN	MAX	UNITS
I_{CBO}	$V_{CB}=90\text{V}$		10	nA
I_{EBO}	$V_{EB}=5.0\text{V}$		10	nA
BV_{CBO}	$I_C=100\mu\text{A}$	120		V
BV_{CEO}	$I_C=30\text{mA}$	80		V
BV_{EBO}	$I_E=100\mu\text{A}$	7.0		V
$V_{CE(SAT)}$	$I_C=150\text{mA}, I_B=15\text{mA}$		0.2	V
$V_{CE(SAT)}$	$I_C=500\text{mA}, I_B=50\text{mA}$		0.5	V
$V_{BE(SAT)}$	$I_C=150\text{mA}, I_B=15\text{mA}$		1.1	V
h_{FE}	$V_{CE}=10\text{V}, I_C=0.1\text{mA}$	50		
h_{FE}	$V_{CE}=10\text{V}, I_C=10\text{mA}$	90		
h_{FE}	$V_{CE}=10\text{V}, I_C=150\text{mA}$	100	300	
h_{FE}	$V_{CE}=10\text{V}, I_C=500\text{mA}$	50		
h_{FE}	$V_{CE}=10\text{V}, I_C=1.0\text{A}$	15		
f_T	$V_{CE}=10\text{V}, I_C=50\text{mA}, f=1.0\text{MHz}$	100		MHz
C_{ob}	$V_{CB}=10\text{V}, I_E=0, f=1.0\text{MHz}$		12	pF
C_{ib}	$V_{EB}=0.5\text{V}, I_C=0, f=1.0\text{MHz}$		60	pF
NF	$V_{CE}=10\text{V}, I_C=100\mu\text{A}, R_S=1.0\text{k}\Omega, f=1.0\text{kHz}$		4.0	dB

R4 (17-June 2004)

SOT-223 CASE - MECHANICAL OUTLINE

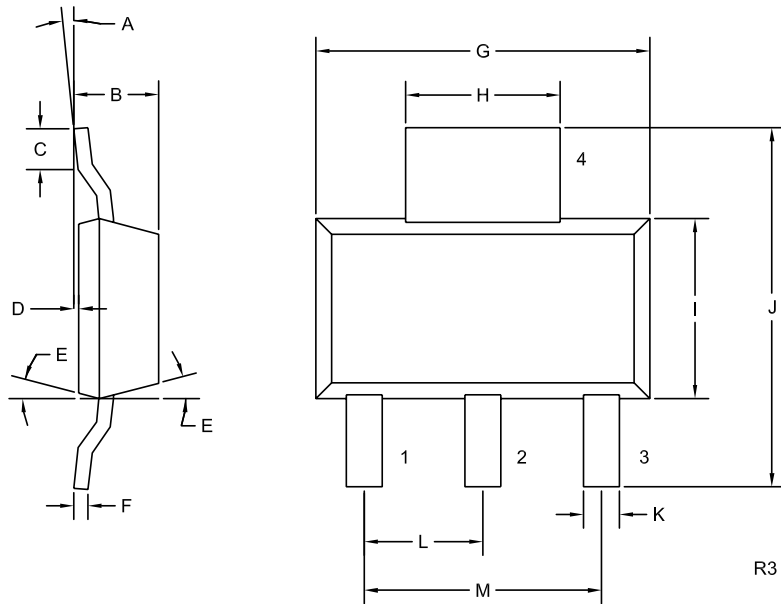

LEAD CODE:

- 1) BASE
- 2) COLLECTOR
- 3) EMITTER
- 4) COLLECTOR

MARKING CODE:

FULL PART NUMBER

DIMENSIONS				
SYMBOL	INCHES		MILLIMETERS	
	MIN	MAX	MIN	MAX
A	0°	10°	0°	10°
B	0.059	0.071	1.50	1.80
C	0.018	---	0.45	---
D	0.000	0.004	0.00	0.10
E	15°		15°	
F	0.009	0.014	0.23	0.35
G	0.248	0.264	6.30	6.70
H	0.114	0.122	2.90	3.10
I	0.130	0.146	3.30	3.70
J	0.264	0.287	6.70	7.30
K	0.024	0.033	0.60	0.85
L	0.091		2.30	
M	0.181		4.60	

SOT-223 (REV: R3)

R4 (17-June 2004)